

Instructions for installation and operation

BEKOMAT®



BEKOMAT® 2

BEKOMAT® 2 CO

BEKOMAT® 2 PN 63

BEKOMAT® 3

BEKOMAT® 3 CO

BEKOMAT® 6

Dear Customer,

we would like to thank you for having decided on the BEKOMAT. If the BEKOMAT is correctly installed we assure you that this condensate drain will reliably fulfil its job and consequently upgrade your compressed air system. Therefore: Please read the installation and operation instructions very carefully and observe our advices before installation and commissioning of your new electronically level-controlled BEKOMAT condensate drain. Only if you pay full attention to the instructions and advices we can guarantee perfect functioning and thus a reliable condensate discharge.

If you have any further questions, our qualified staff will be pleased to help you.



CONTENTS

MODEL VARIATIONS	2
IMPORTANT NOTE	2
FUNCTION	3
NOTES FOR INSTALLATION	4
EXAMPLES OF INSTALLATION	4
MAINTENANCE AND TESTING	7
DESCRIPTION OF ELECTRICAL FUNCTIONS	8
CIRCUIT DIAGRAM	9
ELECTRICAL DATA	9
TECHNICAL DATA	10
DIMENSIONAL DRAWINGS	11

MODEL VARIATIONS

The BEKOMAT is available in three basic variations: BEKOMAT 2, BEKOMAT 3, BEKOMAT 6. They are designed for different operating pressures: 16 bar, 25 bar and 63 bar ("pressures" stated in this text always refer to maximum working pressure) and are offered with different types of housing: BEKOMAT (standard) with aluminium housing for oil-contaminated condensate, BEKOMAT CO with hard-coated aluminium housing for oil-free, aggressive condensates, BEKOMAT models with stainless steel housing for extremely aggressive condensates (not BEKOMAT 2).

In locations where there is a danger of frost the BEKOMAT should be installed with a thermostat regulated heating (see page 9).

Furthermore, there are specific solutions - described in separate operating instructions - for dealing with the problems of special applications: The BEKOMAT Ex can be employed in hazardous locations and has an intrinsically safe design with PTB approval (not BEKOMAT 2). The stainless steel BEKOMAT 3 E Ex-B, with BVS (Cole Mine Association) approval, has been developed especially for

operation in underground mining.

In the case of multi-stage screw-type compressors and turbocompressors a build-up of negative pressure occurs in the area of the intercoolers during no-load operation. To ensure reliable condensate discharge under these conditions, BEKO have developed the no-load condensate drains BEKOMAT 3 LA/6 LA. The range of variants also comprises the level monitor BEKOMAT 2 Ni, which serves to monitor the liquid level or to signal oil breakthrough in screw-type compressors with oil injection cooling.

IMPORTANT NOTE

1. The collecting container of the BEKOMAT is under pressure. Maintenance and repair work must only be carried out when the condensate drain is in a pressureless and de-energized condition, e.g. after pressing the test switch. Do not exceed the stated operating pressures of 16 bar, 25 bar or 63 bar respectively.

The condensate is discharged under operating pressure. The inlet and outlet piping must be firmly fixed. Only use fittings and hoses specifically designed for the applicable pressure range. Always arrange the condensate discharge in such a way that it

cannot splash against persons or objects.

2. Do not use the test switch for continuous draining.

3. The BEKOMAT condensate drain is designed for the discharge of condensates from compressor stations for compressed air or inert gases. Condensate discharge from compressors for flammable or explosive gases or operation in hazardous locations is only permissible with the BEKOMAT Ex, which has been specifically designed and tested for such applications.

4. In locations where there is a danger of frost the BEKOMAT should be installed with a thermostat regulated heating (see page 9).

Attention: Do not disconnect heating from power if there is a danger of frost.

5. The potential-free alarm contact is not to be used with accessible extra-low-voltage parts.

6. Electrical installation must only be carried out by a properly qualified person.

FUNCTION

SINGLE-POSITION MEASUREMENT

All BEKOMAT 2 variants are equipped with single-position measurement. The following describes the functional characteristics of the BEKOMAT with single-position measurement as exemplified by the BEKOMAT 2.

Fig. 1 Condensate passes through the inlet opening (1) into the collecting container (2). The diaphragm valve is closed, since the pilot-supply line (3) and the solenoid valve (4) ensure pressure compensation above the valve diaphragm (5). The larger space above the diaphragm results in a high closing force. The valve seat remains tightly closed without leakage loss.

Fig. 2 Once the container (2) has filled with condensate, so that the capacitive level sensor (6) emits a signal, the solenoid valve is reversed and the air above the valve diaphragm is expelled. The valve diaphragm lifts off the valve seat (8) and

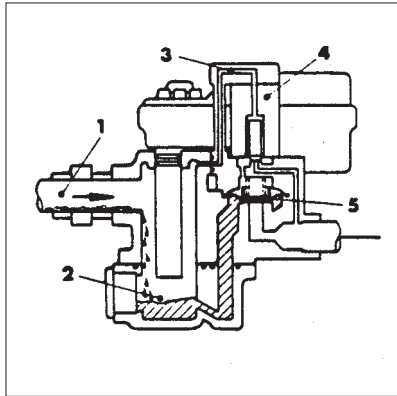

FIG 1: Condensate collection

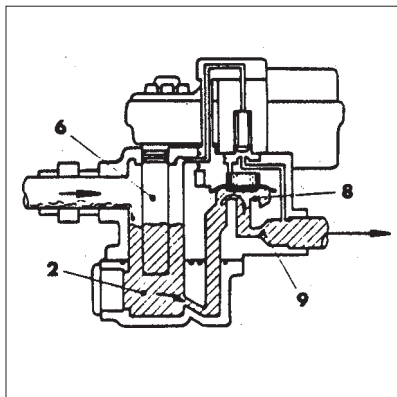

Fig. 2: Condensate discharge

the over pressure in the housing forces the condensate into the discharge pipe (9).

The BEKOMAT electronic system now ensures that the outlet will again be fully closed and leakproof before any compressed air or gas can escape.

In the event of no condensate discharge (blocked discharge pipe, pressure below required minimum), the device will change to the alarm mode after 60 seconds. In this case, the red LED flashes and a potential-free contact is activated. While in the alarm mode, the solenoid valve will open every 4 minutes for a period of 7,5 seconds, so that - instance - any possible obstructions in the discharge pipe could be cleared automatically.

This also means that a device filled in an unpressurized state will automatically be emptied, as soon as the pressure within the BEKOMAT (see page 11) has again risen to the required minimum.

TWO-POSITION MEASUREMENT

All BEKOMAT 3 and BEKOMAT 6 variants are equipped with two-position measurement. The following describes the functional characteristics of the BEKOMAT with two-position measurement as exemplified by the BEKOMAT 3.

Fig. 3 Condensate passes through the inlet opening (1) into the collecting container (2). The diaphragm valve is closed, since the pilot-supply line (3) and the solenoid valve (4) ensure pressure compensation above the valve diaphragm (5). The larger space above the diaphragm results in a high closing force. The valve seat remains tightly closed without leakage loss.

Fig. 4 Once the container (2) has filled with condensate, so that the capacitive level sensor (6) emits a signal at the maximum point, the solenoid valve is reversed and the air above the valve diaphragm is expelled. The valve diaphragm lifts off the valve seat (8) and the over pressure in the housing forces the condensate into the discharge pipe (9).

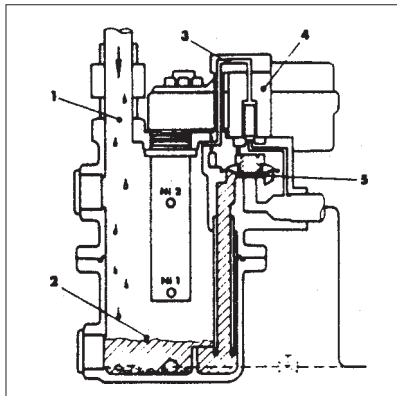

Fig. 3: Condensate collection

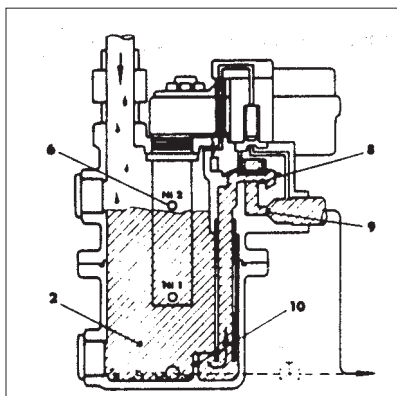

Fig. 4: Condensate discharge

The BEKOMAT electronic system now determines the lowering rate down to the minimum point, and uses this figure for calculating exactly the maximum necessary valve opening time. The valve will again be fully closed and leaktight, before any compressed air can escape.

The outflow barrier (10) ensures that very coarse dirt is trapped at the bottom of the container.

In the event of no condensate discharge (blocked discharge pipe, faulty diaphragm), the device will change to the alarm mode after 60 seconds. In this case, the red LED flashes and a potential-free contact is activated. While in the alarm mode, the solenoid valve will open every 4 minutes for a period of 7.5 seconds, so that - for instance - any possible obstructions in the discharge pipe could be cleared automatically. This also means that a device filled in an unpressurized state will automatically be emptied, as soon as the pressure within the BEKOMAT (see page 11) has again risen to the required minimum pressure.

NOTES FOR INSTALLATION

The following basic rules should always be observed for installation of the BEKOMAT:

1. The condensate must be fed into the BEKOMAT with a continuous downward slope (head) and through a preferably short condensate inlet line. Recommended minimum pipe diameter:

BEKOMAT 2 variants: G ½"

BEKOMAT 3 variants: G ¾"

BEKOMAT 6 variants: G 1" or G ¾"
(see also table)

2. The continuous slope serves to ensure the unimpeded inflow of condensate into the BEKOMAT, whilst allowing the return of air from the container. The device can only fill with condensate, when the inflowing volume of condensate is balanced by a corresponding volume of outflowing air.

3. If for technical reasons only the lower "IN" connection of the BEKOMAT can be used for condensate inflow, then the air exchange described under 2. is only assured in conjunction with a balance air pipe connected at one of the upper "IN"

connections. There must be the same pressure prevailing at the entrance and exit points of the balance air pipe. The recommended minimum pipe diameter amounts to ¼" (or G ½" in the case of BEKOMAT 6 variants). The balance air pipe connection at the vessel to be drained (exit) must lie above the max. possible condensate level.

BEKOMAT 3 variants:

Equally, installation of such a balance air pipe is always required, when the condensate flow rate exceeds 120 l/h, which may generally be the case with a compressor performance above 40 m³/min during summer temperatures.

BEKOMAT 6 variants:

BEKOMAT 6 variants must always be fitted with a flexible air pipe (min. ½") as described above under item 3.

This type of installation is explained further in the following examples of installation and associated drawings.

4. The condensate discharge pipe must be fixed to the wall with a rising slope of no more than 5 m length.

Here, it should be taken into account that the minimum operating pressure required (see page 11) will increase by about 0.1 bar per metre of level difference.

5. It is only permissible to join several condensate discharge pipes to one collecting pipe, if all the relevant discharge pipes are subject to the same pressure. With different pressures, e.g., in the case of multi-stage compressors, there must be a separate collecting pipe for each pressure level. The collecting pipe must measure at least G 1", and there should be an atmospheric pressure of $p_g = 0$ bar at the pipe exit point. The collecting pipe must never be closed by a valve or similar fitting.

6. Do not use any conical pipe joints, since this may damage the threaded connections.

CAUTION

If above notes are disregarded during installation, proper functioning of the BEKOMAT can no longer be guaranteed. The same applies with respect to the following examples of installation.

	Condensate inlet		Condensate outlet	
	Connection "IN"	Piping	Connection "OUT"	Piping
BEKOMAT 2*	2 x G ½"	min. ½"	G ½"	min. ½"
BEKOMAT 3	3 x G ¾"	min. ¾"	G ½"	min. ½"
BEKOMAT 6	1 x G 1" 2 x G ¾"	min. 1" or ¾"	G ½"	min. ½"

* BEKOMAT 2 PN 63: G ½" with undercut for screwed pin DIN 3852 size X

EXAMPLES OF INSTALLATION

IMPORTANT

During installation and operation the "NOTES FOR INSTALLATION" and the "EXAMPLES OF INSTALLATION" must be observed at all times. The following examples of installation represent merely a selection of the instal-

lation options possible in practice. In our experience most cases of malfunctioning of the BEKOMAT are due to incorrect installation. It should therefore be realised that installation errors can cost a great deal in terms of time and money.

If your particular application requirements are not considered in the following examples or if there are still further points you would like to clarify, please contact your supplier.

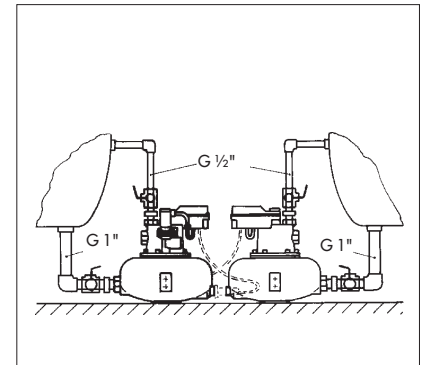
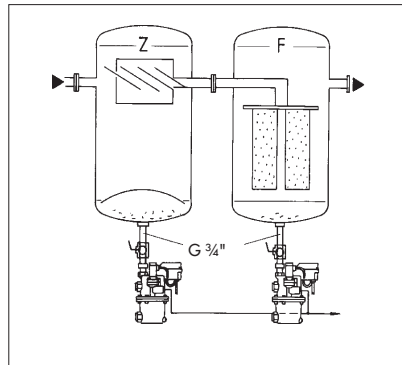
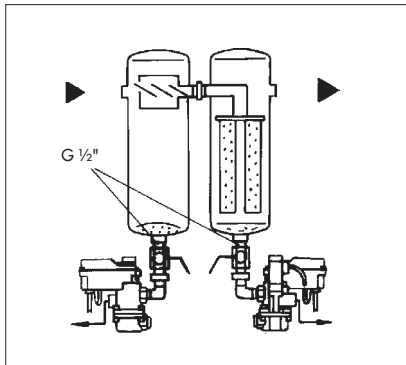
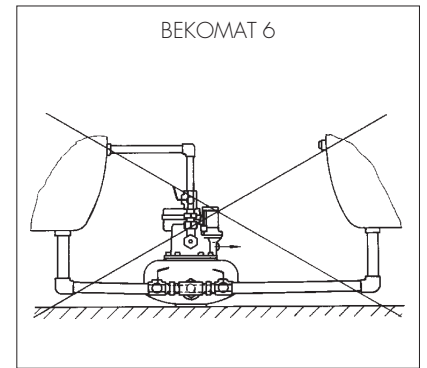
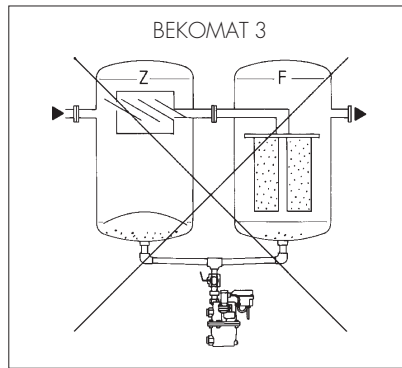
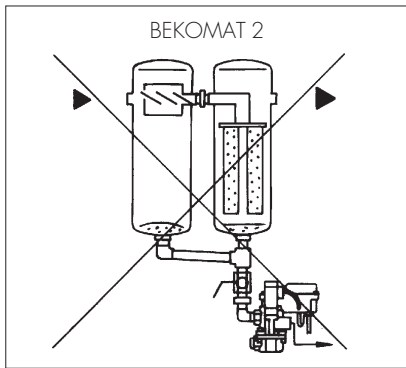

Never join several condensate sources for the purpose of draining. The pressure difference between such condensate sources can cause a bypass flow in the pipes leading to the condensate drain, so that continuous draining would no longer be possible.

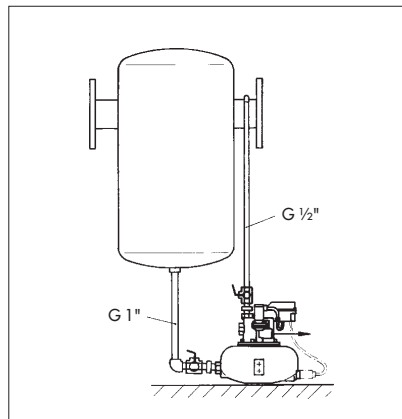
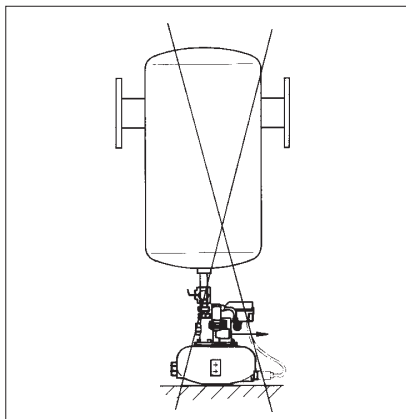

The BEKOMAT 6 is designed for large condensate quantities. Therefore, installation must as a rule include a condensate feed pipe and a separate balance air pipe for air intake and venting.

Caution: There must be the same pressure potential at the in- and outlet of the balance air pipe. Furthermore, it must be ensured that the balance air pipe runs back to a point above condensate level of the vessel to be drained.

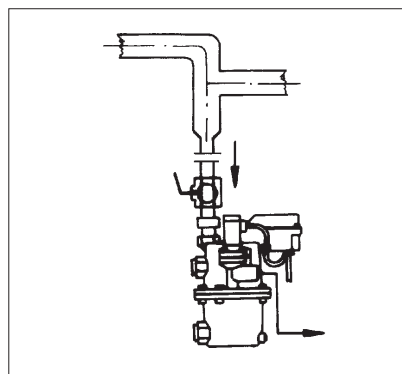
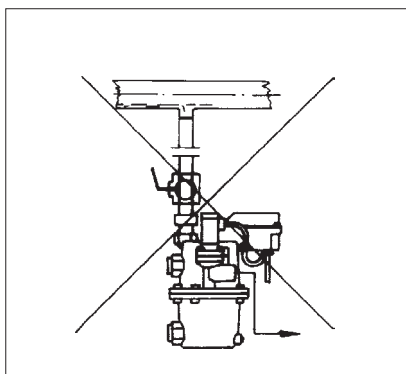

When draining from a piping system, the BEKOMAT unit must always be positioned at the lowest point and the piping must be laid in such a way that the condensate flows to this lowest point. If this is not observed, the condensate can be trapped in water pockets or entrained by the flow of compressed air.

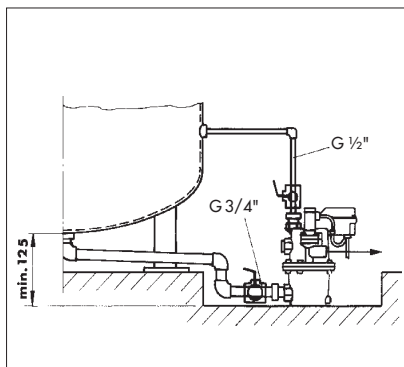
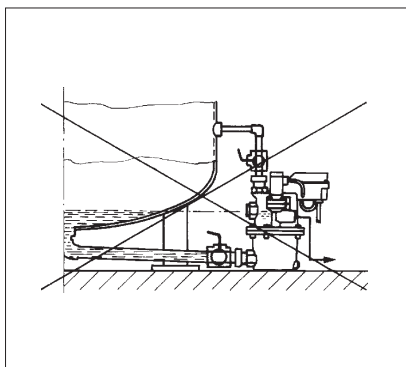

The floor clearance underneath the vessel to be drained must be at least:
 BEKOMAT 2: 70 mm
 BEKOMAT 3: 125 mm
 BEKOMAT 6: 163 mm
 Otherwise the condensate accumulates in the vessel and the BEKOMAT could change to the alarm mode during draining because of the liquid head being too high.

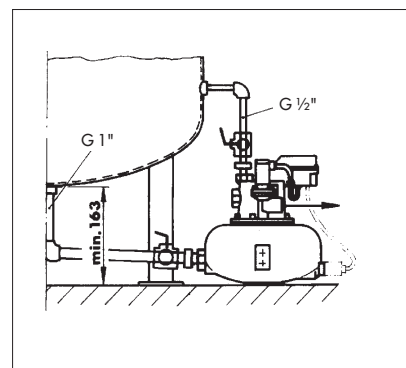
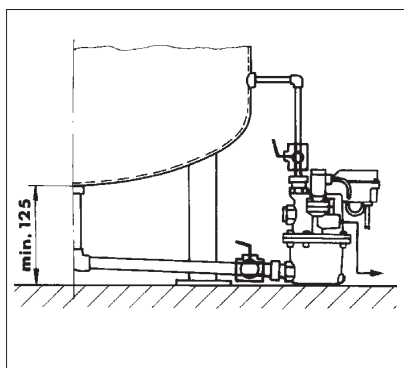
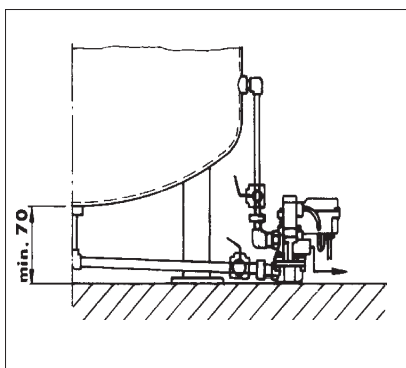
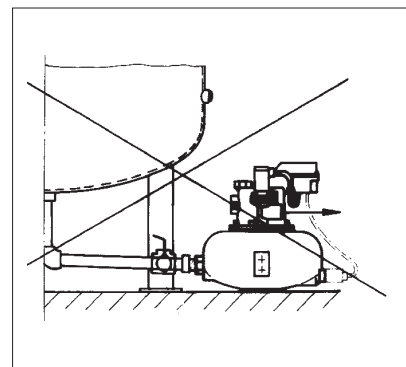
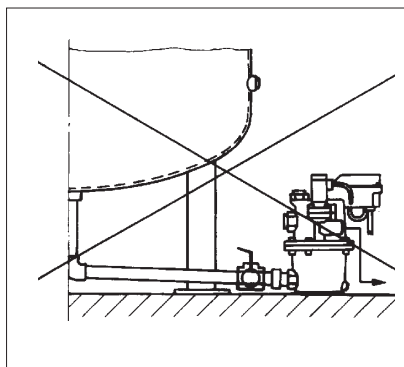
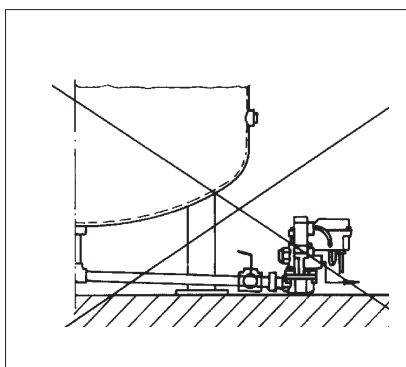
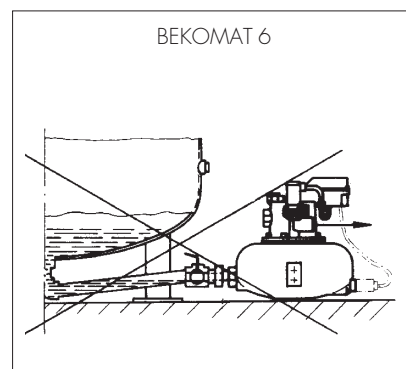
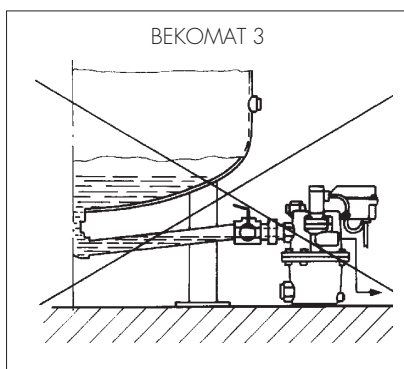
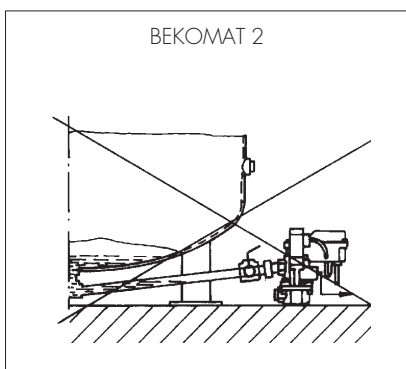

The condensate must always flow into the BEKOMAT with a downward slope (see also page 4 "NOTES FOR INSTALLATION", 2.). If for technical reasons the condensate inlet can only be fitted to the lower "IN" connection of the BEKOMAT, then one of the upper "IN" connections (BEKOMAT 2 variants only have one upper connection) must be fitted with a separate balance air pipe running back to a point above condensate level of the vessel to be drained. The pressure potential at the in- and outlet of the balance air pipe and the inlet pipemust be equal.

In the case of a compressor performance > 40 m³/min, BEKOMAT 3 variants must be installed as a rule with a condensate feed pipe and a separate balance air pipe, as shown in the above drawings.

The BEKOMAT 6 should always be installed with a separate balance air pipe because of the large condensate quantities involved (G 1/2" or bigger).

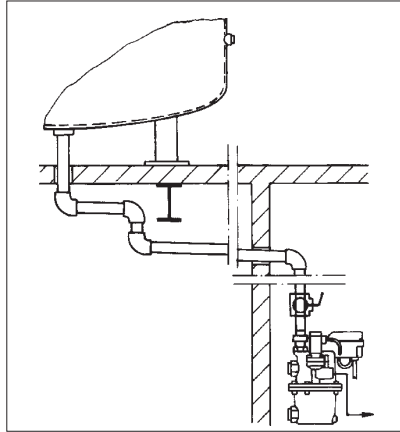
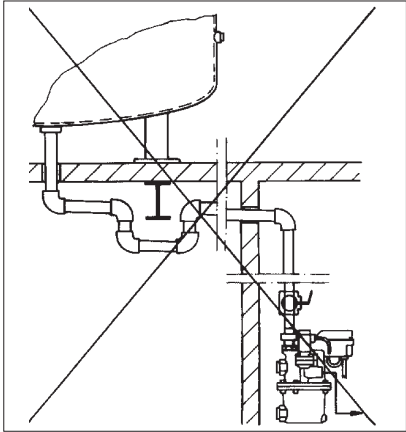

The feed pipe leading to the BEKOMAT must be laid with a continuous slope, i.e. without rising sections (all BEKOMAT 2/3/6 variants). Otherwise air intake and venting of the BEKOMAT might be affected (see page 4 "NOTES FOR INSTALLATION", 2.).

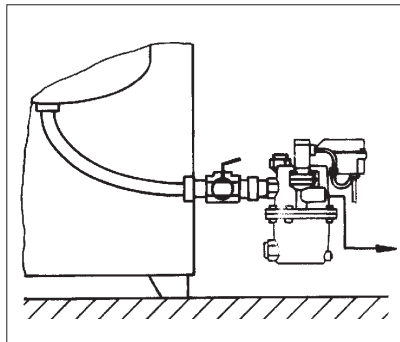
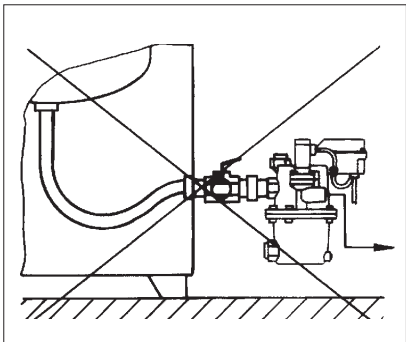

If a hose serves as a feed line to the BEKOMAT (all BEKOMAT 2/3/6 variants), it must show a continuous slope; otherwise this might interfere with the air intake and venting of the BEKOMAT.

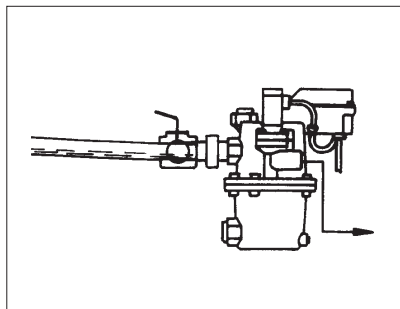
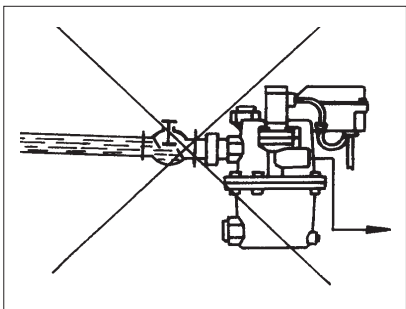

Only use ball valves as shutoff valves. The feed pipe should be laid throughout with a cross-section of at least:

BEKOMAT 2: G 1/2"

BEKOMAT 3: G 3/4"

BEKOMAT 6: G 1" or 3/4"

Laying of smaller cross-sections may disturb the inflow of condensate as well as the air intake and venting processes.

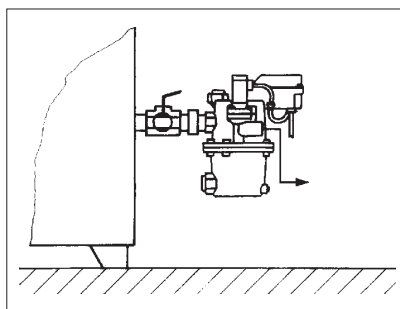
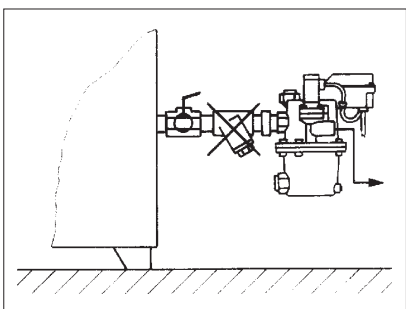

Do not insert any filters or strainers into the feed pipe to the BEKOMAT (all BEKOMAT 2/3/6 variants). Remove the entire filter or strainer housing, where applicable.

MAINTENANCE AND TEST

Maintenance of the BEKOMAT will only be necessary in exceptional cases, since any malfunction is automatically indicated by the electronic system. In order to ensure that a possible malfunction is noticed immediately by your operating personnel, it is recommended to relay the fault signal via a potential-free contact (fitted as a standard) to a central monitoring station.

The BEKOMAT will normally give years of trouble-free operation. For safety reasons, it is recommended to clean valve and housing once a year and to replace any parts subject to wear, such as diaphragm, valve core, and seals. For this purpose, we can supply a complete set of wearing parts.

Performance test: During the routine

check patrols it is advisable to verify occasionally the correct performance of the device by pressing the test switch. For checking the potential-free alarm contact, shut off the condensate inflow and press the test switch for one minute. This should result in the alarm signal being relayed.

DESCRIPTION OF ELECTRICAL FUNCTIONS

BEKOMAT 2 VARIANTS

The BEKOMAT 2 series is equipped with a specially developed electronic PCB, which allows a controlled discharge of condensate.

The condensate level is registered by one capacitive probe (single-position measurement) connected to the PCB. Waveform comparison serves to detect whether the probe has been covered up to a predefined level. If that is the case, the discharge procedure is started after a delay of approx. 0.6 seconds, and the alarm/monitoring circuit is activated at the same time. The circuit then regulates the further discharge procedure.

Normally, the solenoid valve is opened for approx. 0.4 seconds, the condensate drain is emptied, and the discharge procedure comes to an end, while the alarm/monitoring circuit is deactivated. The BEKOMAT is controlled by an electronic switching system enabling controlled and monitored condensate discharge independent of pressure.

In the event of no condensate discharge, e.g., if the condensate discharge pipe is blocked or the pressure drops below the required minimum (see page 11) the alarm/monitoring circuit will regulate the further sequence of functions (see section "Alarm/monitoring control, 2.").

BEKOMAT 3/6 VARIANTS

With these variants, the condensate level and the discharge times are determined with the aid of two capacitive probes (two-position measurement) arranged in a vertical line along a sensor tube and connected to a waiting circuit. Information on the respective states of the upper and lower probe is obtained by waveform comparison. When both probes are covered by condensate, the discharge procedure is started - after a delay of approx. 2 seconds - and the alarm/monitoring circuit is activated. As soon as the solenoid valve opens, i.e. when the condensate discharge starts, the electronic system determines the pressure-dependent time required until the lower probe will again be free of condensate.

This figure serves as a basis for calcu-

lating the necessary opening time of the solenoid valve up to final discharge without loss of compressed air. At the end of this period, the BEKOMAT will be completely empty; the discharge procedure is then stopped, and the alarm/monitoring circuit is deactivated.

In the event of no condensate discharge, e.g., if the condensate discharge pipe is blocked or the pressure drops below the required minimum (see page 11) the alarm/monitoring circuit will regulate the further sequence of functions (see below "Alarm/monitoring control", 1. and 2.).

ALARM/MONITORING CONTROL

The BEKOMAT electronic system ensures permanent monitoring of the operating states of the condensate drain. Any malfunctions will be signalled via the potential-free alarm contact. The control operates in a fail-safe mode. Consequently, an alarm signal can still be relayed via the potential-free contact, if the power supply to the BEKOMAT is interrupted. The circuit diagrams on page 9 show the de-energised state of the BEKOMAT with the potential-free alarm contact 3.0-3.1 closed (alarm mode). When voltage is applied, the alarm relay picks up and terminals 3.1-3.2 of the potential-free contact are closed (normal operating state). In the case of a malfunction, the alarm relay drops out and terminals 3.0-3.1 are connected (alarm mode).

1. With the BEKOMAT 3/6 variants (two-position control) the situation may arise where the discharge procedure is started, but the lower probe remains covered, so that the required opening time of the solenoid valve cannot be calculated. In this case, the discharge procedure is interrupted after approx. 2.5 sec., and is only restarted when the upper probe is covered again.

2. Under certain conditions mentioned above, the probe of the BEKOMAT 2 variants (single-position measurement) or the lower and upper probe of the BEKOMAT 3/6 variants may remain permanently covered. In this case, the discharge procedure is

interrupted after approx. 2.5 seconds and restarted after a delay of approx. 2 seconds. This procedure is then repeated until the alarm signal is triggered.

The alarm signal occurs after approx. 60 seconds, and the alarm circuit takes over the subsequent control of the solenoid valve.

In the alarm mode, the solenoid valve is first closed, and the alarm relay drops out, while the potential-free changeover contact goes into off-position. The alarm signal is maintained, and the alarm circuit actuates the solenoid valve approx. every 4 minutes for a period of approx. 7.5 seconds. The alarm mode LED continues to flash. This switching function is repeated until the condensate drain is again operating under normal conditions.

The solenoid valve can be actuated by means of the test switch at any time; the valve will stay open as long as the switch is being pressed. During testing, the red LED flashes and, after pressing the test switch for about one minute, an alarm signal is given via the potential-free contact. After releasing the test switch, the condensate drain will revert to normal operation.

The circuitry of the BEKOMAT is designed in such a way that - after relevant changes of the PCB components and correct adjustments, which must be done at our works - it can also function with direct voltage. In addition to mounting the necessary components on the printed circuit board, d.c. operation requires fitting of a special solenoid coil.

LED power: (green) operating state 'power supply' (LED on = voltage is applied).

LED valve: (yellow) indication of actuated solenoid valve (LED on = solenoid valve open).

LED alarm: (red) alarm and test state indication with flashing frequency of 2 - 3 times per second.

CIRCUIT DIAGRAMS

Circuit diagram BEKOMAT 2-variants

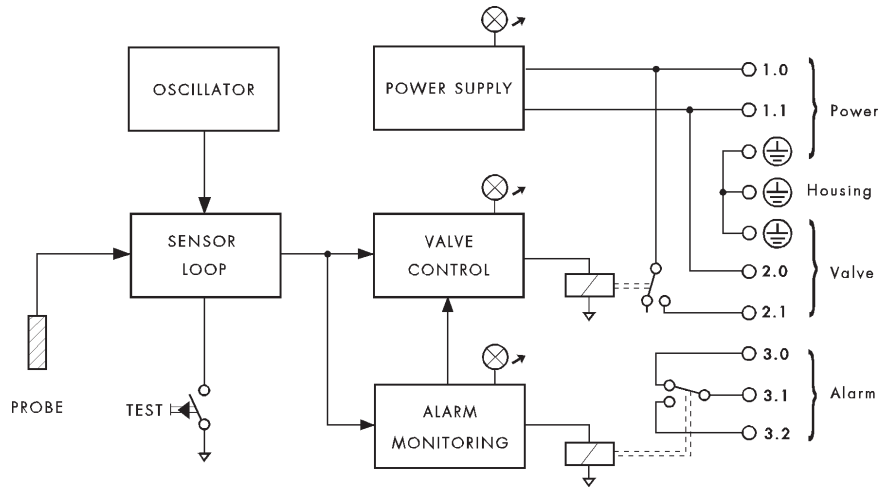

Circuit diagram BEKOMAT 3/6-variants

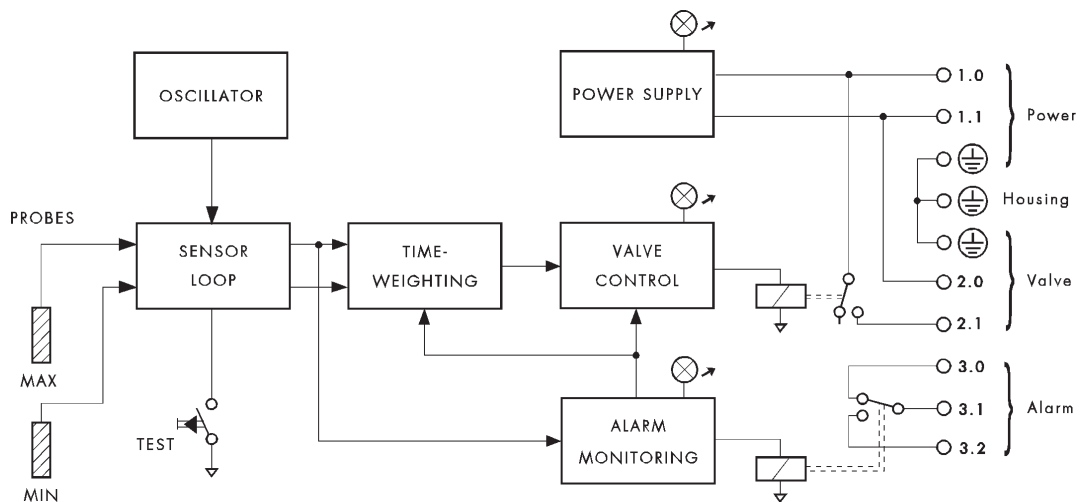

ELECTRICAL DATA

BEKOMAT 2/3/6-variants

TERMINAL STRIP ASSIGNMENT

1.0	Power supply "L1"
1.1	Power supply "N"
PE	Earth connection for power supply
PE	Internal earth connection for device
PE	Earth connection for valve solenoid
2.0	Valve solenoid "N"
2.1	Valve solenoid "V1"
3.0	Potential-free contact "off"
3.1	Potential-free contact "centre"
3.2	Potential-free contact "on"

ELECTRICAL DATA

Power supply:	230 V / 50 - 60 Hz (standard) *
Power input:	1.8 VA without solenoid valve 9.8 VA with solenoid valve
Alarm contact:	For direct voltage and alternating voltage max. 125 W or 125 VA E < 250 V / I < 0.5 A I min = 100 mA for dry-circuit conditions
Cross-section for connection:	3 x 0.75 mm ²
Recommended external fuse:	0.5 A slow-blowing

*) Special voltages: 110 V / 50 - 60 Hz
24 V / 50 - 60 Hz
24 Vdc

BEKOMAT 2/3/6-variants with special voltage 24 Vdc

TERMINAL STRIP ASSIGNMENT**

ELECTRICAL DATA

1.0 +L (positive pole-insulated conductor)		+	Power supply:	24 Vdc
1.1 - L (negative pole-housing earthed)		-	Power input:	10 W (mean value) without heating
PE - L (negative pole-housing earthed)		-	Alarm contact:	max. 110 W or 110 VA
PE Internal earth connection for device				E < 250 V / I < 0.5 A
PE Earth connection for valve solenoid				I min = 100 mA for dry-circuit conditions
2.0 Valve solenoid "N"			Cross-section for connection:	2 x 0.75 mm ²
2.1 Valve solenoid "V1"			Recommended external fuse:	1.0 A (slow-blowing)
3.0 Potential-free contact "off"				
3.1 Potential-free contact "centre"				
3.2 Potential-free contact "on"				

***) The connection "PE" and terminal "1.1" is not absolutely essential, since the circuit has been fitted on the soldering side with an SMD resistor or SMD diode. This safety measure ensures polarity reversal protection in connection with the power supply.

TECHNICAL DATA

	Peak period condensate quantity l/h	Peak compressor performance m ³ /min	Peak refrigeration dryer performance m ³ /min	Ambient temperature **) min./max. °C	Operating pressure bar	Weight kg	Appli- cation *)
BEKOMAT 2	70	10	20	+1/+60	0,8/16	1,1	1
BEKOMAT 2 CO	70	10	20	+1/+60	0,8/25	1,1	2 (1)
BEKOMAT 2 PN 63	70	5	10	+1/+60	1,2/63	1,1	2 (1)
BEKOMAT 3	700	100	200	+1/+60	0,8/16	2,5	1
BEKOMAT 3 CO	700	100	200	+1/+60	0,8/25	2,5	2 (1)
BEKOMAT 3 E 25	700	100	200	+1/+60	1,2/25	5,8	3 (1, 2)
BEKOMAT 3 E 63	700	100	200	+1/+60	1,2/63	5,8	3 (1, 2)
BEKOMAT 6	1.700	1.000	2.000	+1/+60	0,8/16	5,9	2 (1)
BEKOMAT 6 E 25	1.700	1.000	2.000	+1/+60	1,2/25	14	3 (1, 2)

*) 1 = oil-contaminated condensate ==> Aluminium-housing (material: Gk Al Si 10 Mg)
 2 = oil-free, aggressive condensate ==> Aluminium-housing (material: Gk Al Si 10 Mg) with 50 mm HARD-COAT-surface finish
 3 = extremely aggressive condensate ==> Stainless steel housing (material: 1.4581)

**) Whenever a thermostat regulated heating and correct thermal insulation are used, the BEKOMAT (not valid for Ex-version) can be installed in temperatures down to - 25 °C.

DIMENSIONAL DRAWINGS

BEKOMAT 2 - VARIANTS

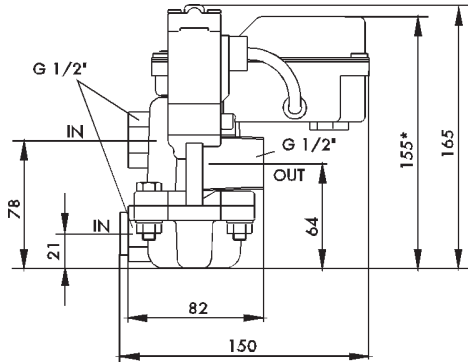

*) Max. height measurement for BEKOMAT 2 CO and BEKOMAT 2 PN 63

BEKOMAT 3 - VARIANTS

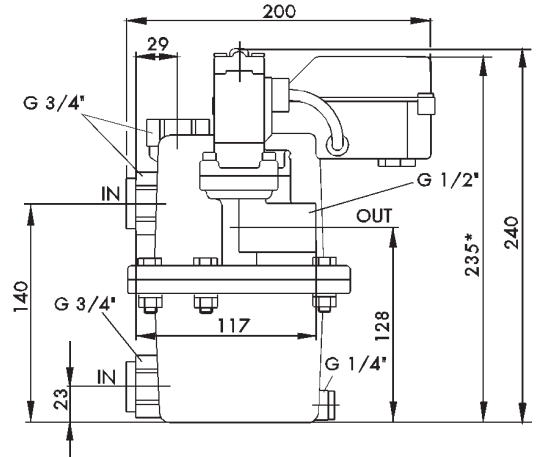

*) Max. height measurement for BEKOMAT 3 CO / 3 E 25 / 3 E 63

BEKOMAT 6 - VARIANTS

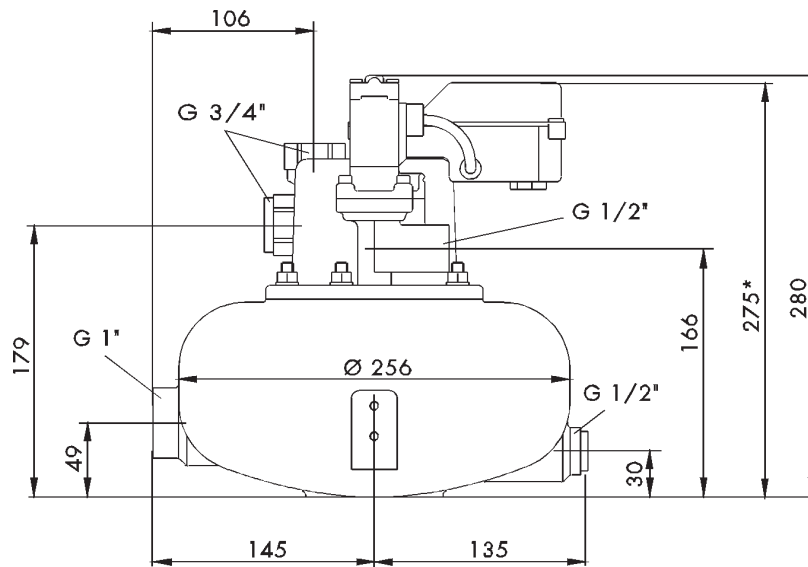

*) Max. height measurement for BEKOMAT 6 E25

