

METPOINT® OCV

**SAFE PROCESS
THROUGH MONITORING**

**FOR CHALLENGING
COMPRESSED-AIR APPLICATIONS**

- e.g.**
- Pharmaceuticals
 - Food
 - Chemical
 - Coating



METPOINT® OCV PAYS ATTENTION

MONITORED FREEDOM FROM OIL

Oil-contaminated compressed-air is a concern for every compressed-air user. Depending on the use, there are risks for production plants, the environment or even for health. One thing is for sure: even oil-free compressors are no guarantor for "oil-free" compressed-air because of the ambient air/intake air. In most cases, a certain residual oil content cannot be avoided in standard applications.

The compressed-air classes defined in ISO 8573-1 provide an orientation for the assessment of compressed-air quality.

COMPRESSED-AIR GAINS IN SAFETY

METPOINT® OCV continuously monitors the residual oil content of the flowing compressed-air. Samplings and time-consuming laboratory analyses are no longer required. Moreover, the acquisition costs of a METPOINT® OCV system are insignificant compared with the consequential costs of a production stop.

EXTRACT FROM ISO 8573, PART 1

7.3 Oil classes – Table 5

Classes	Oil concentrations (aerosol, liquid and vapour)
Class 0	Specified by operators and suppliers
Class 1	≤ 0.01 mg/m ³
Class 2	≤ 0.1 mg/m ³
Class 3	≤ 1 mg/m ³
Class 4	≤ 5 mg/m ³





+ 1: PERMANENT ONLINE MEASUREMENT

+ 2: TÜV ZERTIFIZIERTES MESSVERFAHREN

+ 3: NETWORK-COMPATIBLE - STATE-OF-THE-ART IT CONNECTION

+ 4: TOUCH SCREEN DISPLAY

WHAT IS METPOINT® OCV CAPABLE OF?

METPOINT® OCV was developed for the detection of vaporous hydrocarbons. It is designed for the stationary measurement and monitoring of vaporous residual oil content in compressed-air (ISO 8573:2001).

WHAT DAMAGE CAN BE PREVENTED BY METPOINT® OCV?

METPOINT® OCV can be applied to protect production and products. The data acquired are used both for the documentation of the compressed-air quality and for the identification of contamination sources.

- Contamination of pipeworks
- Contamination of products
- Damage to machines and plants
- High costs of repair and rejects

HOW DOES OIL VAPOUR GET INTO THE COMPRESSED-AIR SYSTEM?

Oil vapour is usually already contained in the induced air, and reappears in the compressed-air in a concentrated form. In addition, oil vapours can reach the compressed-air system as a result of the compression process (oil-injected compressors) or through oils and greases applied as lubricants, or sealing components in compressed-air treatment systems.

METPOINT® OCV FOR CHALLENGING APPLICATIONS

SOME TYPICAL EXAMPLES OF OIL-FREE COMPRESSED-AIR IN PRACTICE

Chemical

Compressed-air is used for the mixing of different materials. Materials to be mixed are blended in a silo by means of compressed air. The precondition for a perfect end product is processed and oil-free compressed-air.

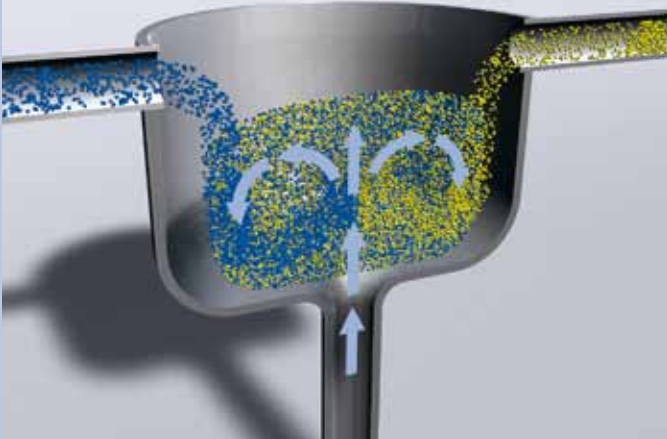

Food

Prior to filling, bottles are cleaned and dried with compressed-air. Oil in the compressed-air would accrete on the inner surface of the bottle and subsequently blend in the product. Oil-free compressed-air is an essential production factor for a high quality end product.



Coating

During paint coating / coating, compressed-air is used to transfer the paint from the spray gun to the substrate, amongst other uses. Oil-contaminated compressed-air leads to lacquering defects. For example, the paint no longer adheres faultlessly to the painting surface.



Pharmaceutical industry

During the production of tablets, dust is removed downstream of a tablet press using compressed-air. The quality of compressed-air is of decisive importance for hygienic safety.

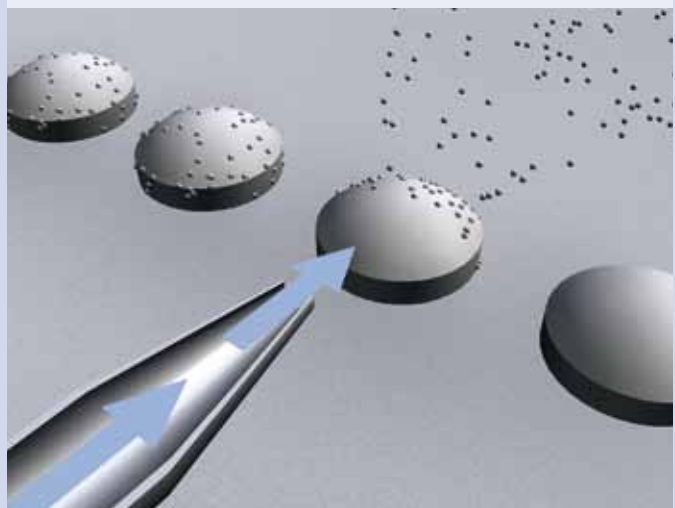

**Installation diagram METPOINT® OCV
with an oil-free compressor**

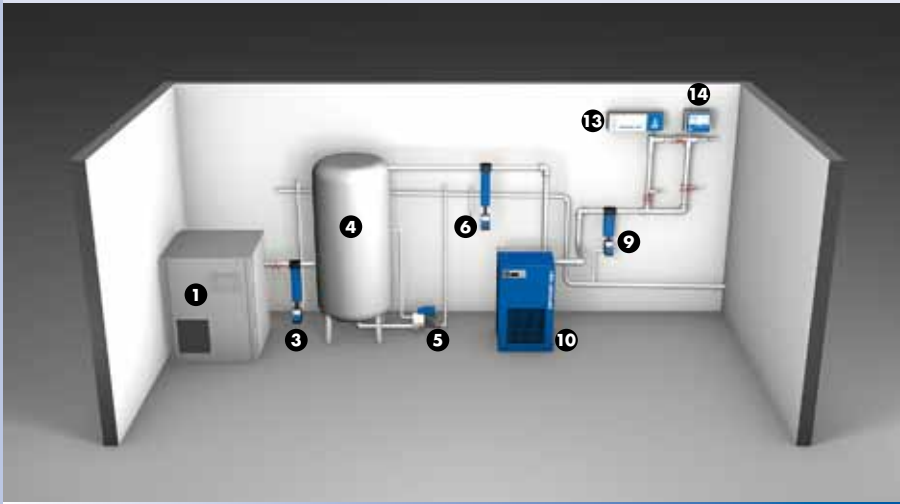

- ❶ Compressor (oil-free)
- ❷ Compressor (oil-lubricated)
- ❸ Water separator with BEKOMAT®
- ❹ Compressed-air tank
- ❺ BEKOMAT® for the tank drainage
- ❻ Universal filter (G) with BEKOMAT®

Installation diagram METPOINT® OCV with activated-carbon adsorber

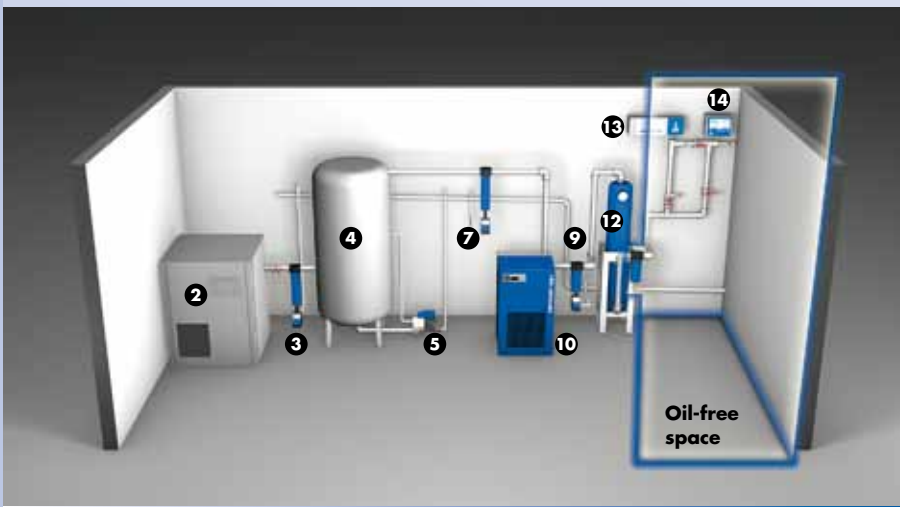

- ❷ Compressor (oil-lubricated)
- ❸ Water separator with BEKOMAT®
- ❹ Compressed-air tank
- ❺ BEKOMAT® for the tank drainage
- ❻ Universal filter (G) with BEKOMAT®
- ❼ Fine filter (F) with BEKOMAT®
- ❽ Dust filter (F) with BEKOMAT®
- ❾ Super-fine filter (S) with BEKOMAT®
- ❿ Minimum requirement: refrigeration dryer
- ⓫ BEKOKAT®
- ⓬ Activated-carbon adsorber
- ⓭ Sensor unit METPOINT® OCV

Installation diagram METPOINT® OCV with BEKOKAT®

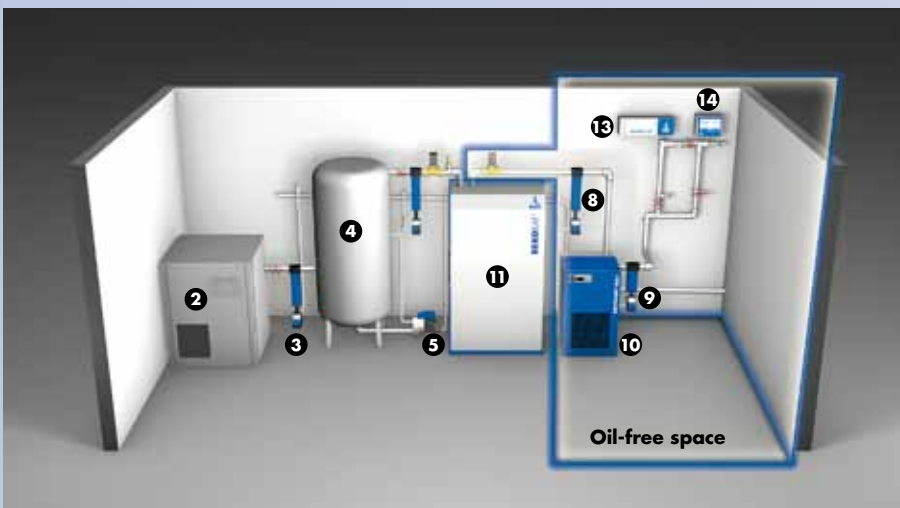

- ⓫ BEKOKAT®
- ⓬ Activated-carbon adsorber
- ⓭ Sensor unit METPOINT® OCV
- ⓮ Evaluation unit with user interface METPOINT® OCV



WORKING PRINCIPLE OF METPOINT® OCV

METPOINT® OCV is a measuring system for the detection of hydrocarbon vapours. Samples, continuously taken from the flowing compressed-air, are supplied to the sensor unit via a rising main. In the sensor unit, the hydrocarbon vapour proportion is measured using a PID (photoionisation detector).

The resulting electrical signal is amplified and evaluated. The results are shown on the touch screen display and simultaneously recorded in the internal memory (2 GB – recording time of up to 10 years). An alarm is triggered when a freely-programmable value is exceeded.

STRUCTURE

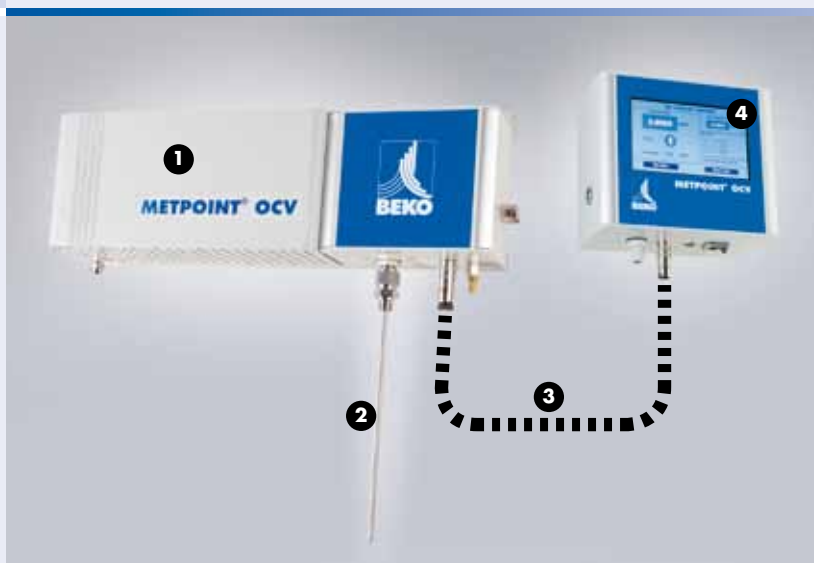

- ❶ Sensor unit
- ❷ Sampling probe
- ❸ Signalling cable
- ❹ Evaluation unit with touch screen display

SAMPLING

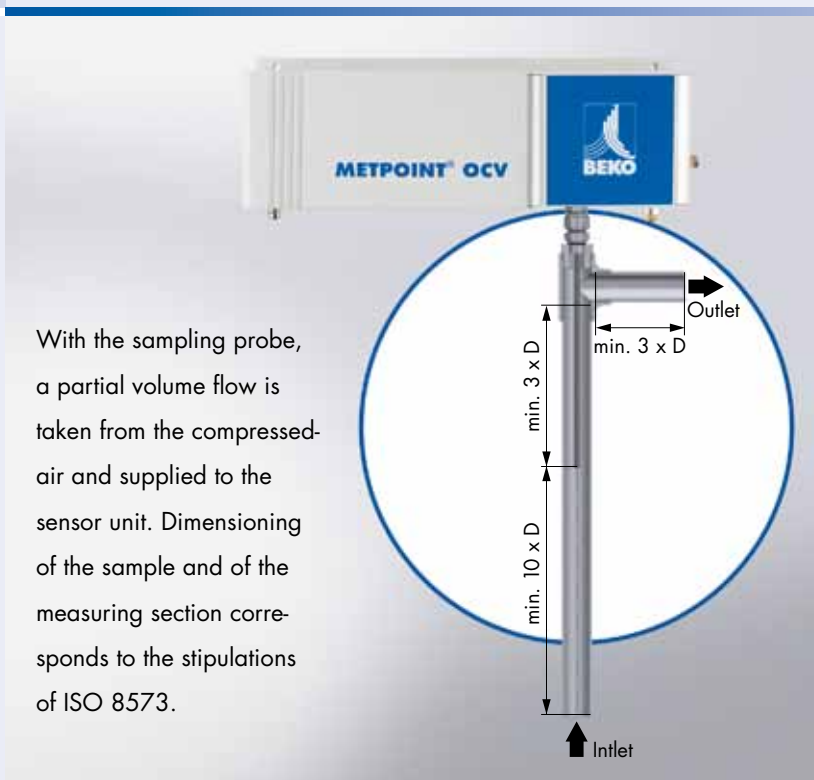

With the sampling probe, a partial volume flow is taken from the compressed-air and supplied to the sensor unit. Dimensioning of the sample and of the measuring section corresponds to the stipulations of ISO 8573.

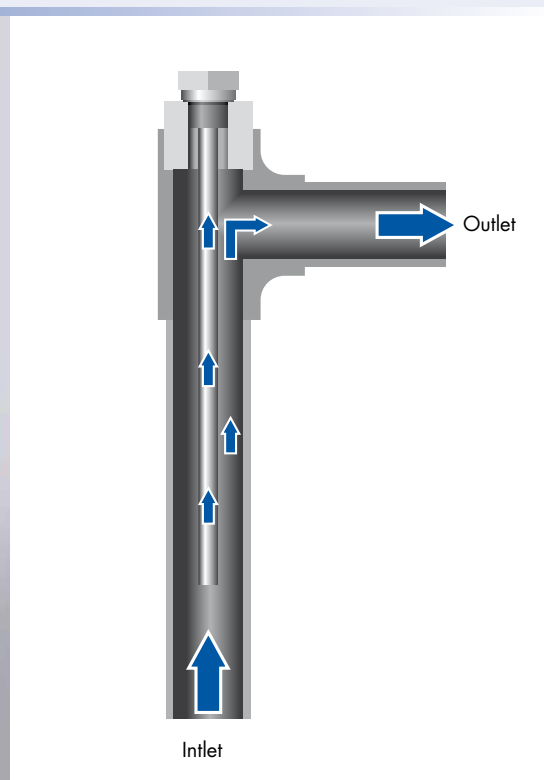

MEASUREMENT

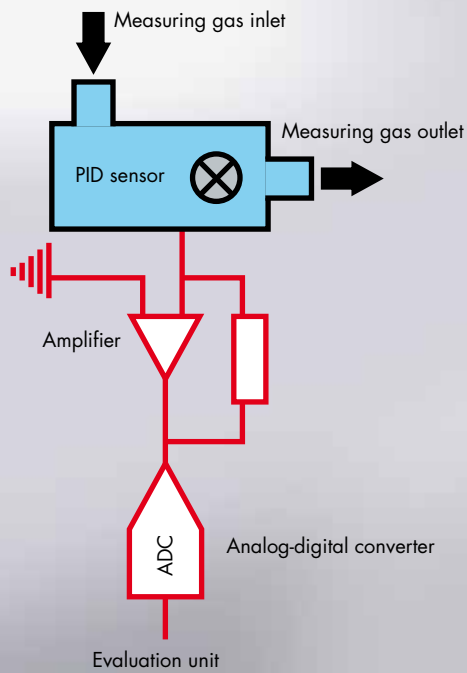

The sensor functions according to the photoionisation principle.

The measuring principle of a photoionisation detector (PID) is based on the ionisation of the gas molecules through UV radiation and the registration of the resulting ion current. The electrical signal is measured, electronically evaluated and shown on the display.

EVALUATION



- ❶ Current value
- ❷ Average of last 10 measurements
- ❸ Alarm value
- ❹ Signalling cable
- ❺ Ethernet interface
- ❻ Alarm contact

Optionally available:

- 4-20 mA analog signal

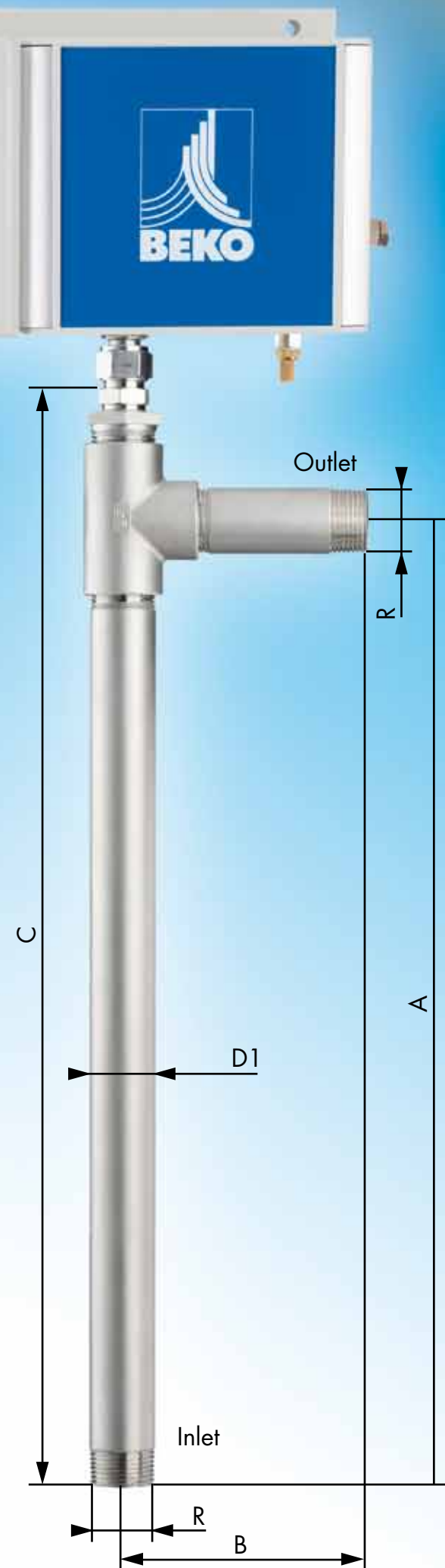

TECHNICAL DATA SENSOR UNIT

Dimensions	487 x 170 x 120 mm (L x H x W)
Power supply	230 VAC 50 Hz +/- 10% or 115 VAC 60 Hz +/- 10%
Medium	Compressed-air
Identifiable substances	Polyalphaolefins aliphatic hydrocarbons hydrocarbons functional hydrocarbons aromatics
Ambient temperature	+5 ... +45 °C
Compressed air temperature	+5 ... +55 °C
Operating overpressure	3 bar ... max. 16 bar (ü) *
Measuring gas humidity	≤ 40 % rel. humidity
Measure unit	mg/m ³ (standard cubic metres in accordance with ISO 1217; 1 bar, 20 °C, 0 % rel. humidity)
Measuring range	≤ 0.01 – 5.000 mg/m ³ residual oil vapour content (according to ISO 8573-1)
Measuring accuracy	0.003 mg/m ³
Detection limit	0.0006 mg/m ³
Connection	G 3/8" internal thread Please observe installation instructions
Installation requirements	Vertically ** into the rising main via oil and grease-free measuring section
Inlet zone	10 x DN (min. 200 mm) / in acc. with ISO 8573-2
Outlet zone	3 x DN (min. 100 mm) / in acc. with ISO 8573-2

* other operating pressure on request
** horizontally on request

TECHNICAL DATA EVALUATION UNIT

Operating temperature	+5 ... +50 °C
Dimensions	230 x 200 x 120 mm (W x H x D)
Outputs	Potential-free change-over contact, 230 VAC 5A or 24 VDC 5A Analog 4–20 mA available option Ethernet interface
Power supply	230 VAC 50 Hz or 115 VAC 60 Hz
Memory	2 GB internal memory

DIMENSIONS OF OPTIONAL MEASURING SECTION

	Type	A mm	B mm	C mm	R	D1 ø mm	PN bar
DN 20	MS-2016	430	120	475	R 3/4"	26.9 x 2.6	16
DN 25	MS-2516	480	120	530	R 1"	33.7 x 3.6	16
DN 32	MS-3216	550	130	610	R 1 1/4"	42.4 x 3.6	16
DN 40	MS-4016	600	180	670	R 1 1/2"	48.3 x 3.6	16
DN 50	MS-5016	905	190	980	R 2"	60.3 x 3.6	16
DN 65	MS-6510	1105	260	1220	R 2 1/2"	76.1 x 3.6	10
DN 80	MS-8010	1155	320	1270	R 3"	88.9 x 4.0	10



POTENTIAL FOR CONTAMINATION

At many points of a compressed-air plant, there is a risk of contamination through oil. Only a systematic analysis of the entire compressed-air generation and processing can define risk potentials and point out solutions. Oil-free compressors are not a 100 % guarantor for oil-free compressed-air, as the compressed-air quality strongly depends on the induction conditions.

This diagram points to possible oil-contamination sources in a typical compressed-air plant.

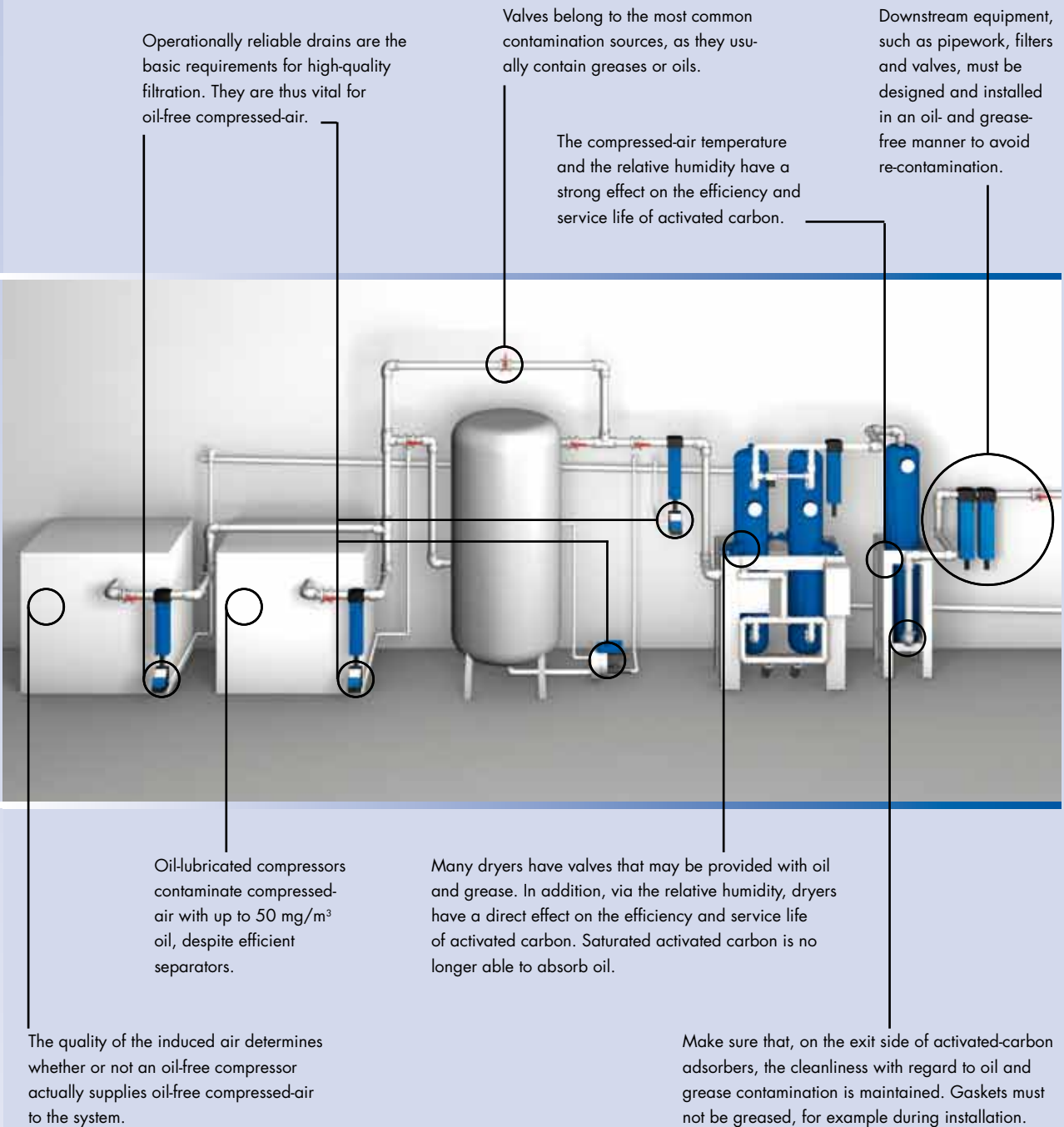

For reliably oil-free compressed-air in accordance with DIN ISO 8573, we recommend BEKOKAT®.
 You will find further information regarding BEKOKAT® and other BEKO components at www.beko.de



BEKO

COMPRESSED-AIR SUPPLY WITH QUALITY

BEKOMAT®

The convincing concept for condensate discharge

ÖWAMAT®

Clean and safe oil/water separation

BEKOSPLIT®

Splitting plants for the reliable, economic and environmentally friendly processing of oil-water emulsions

CLEARPOINT®

Process-reliable and flow-optimised filters and water separators for compressed-air and technical gases

DRYPOINT®

Refrigeration dryers, adsorption dryers, membrane dryers

EVERDRY®

Heat regenerated adsorption dryers for customised applications

BEKOKAT®

Catalytic compressed-air processing for reliably oil-free compressed-air

BEKOBLIZZ®

Optimised cooling processes using ultra-low refrigerated, dry compressed-air

METPOINT®

Measurement technology for the monitoring, control and optimisation of the compressed-air system

BEKOFLOW®

The innovative, cost-reducing compressed-air pipe system

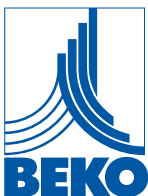

BEKO TECHNOLOGIES GMBH

Im Taubental 7 Telefon +49 2131 988-0
41468 Neuss Telefax +49 2131 988-900
beko@beko.de www.beko-technologies.de



Subject to technical changes without prior notice; the information provided does not represent characteristics of state within the meaning of the German Civil Code (BGB).

© Registered Trademarks by BEKO TECHNOLOGIES GmbH, Neuss

XP MO 001 INT
Edition 2011-03