

CONDENSATE DRAIN

BEKOMAT® 3 VACUUM

BEKOMAT® 6 VACUUM

SPECIAL



Beyond our standard range, BEKO offers a number of special BEKOMAT® condensate drains for applications that are not adequately covered by the usual products in the market.

The vacuum version of our electronically level-controlled BEKOMAT® condensate drains has been designed specifically for the discharge of condensate or other fluids from vacuum systems. Additionally, these condensate drains can also be used for technical processes under standard atmospheric conditions. They extend the scope of application of BEKOMAT® devices to include pressures from 0.1 to 1.8 bar (abs.)

+ 1:



THE BEKOMAT 3 V AND 6 V MODELS CAN ALSO BE SUPPLIED IN STAINLESS STEEL FOR USE WITH AGGRESSIVE CONDENSATE OR OTHER SUCH FLUID

+ 2:

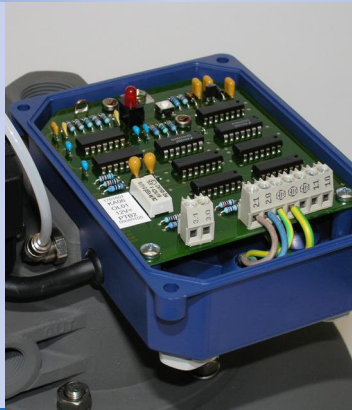

ALL TYPES ARE ALSO AVAILABLE IN EXPLOSION-PROTECTED VERSIONS FOR APPLICATION IN HAZARDOUS AREAS OR FOR THE DISCHARGE OF CONDENSATE FROM EXPLOSIVE GAS MIXTURES. ATEX CERTIFIED WITH BVS 03 ATEX E 214 X AND CLASSIFICATION II 2G EEx ib IIB T4

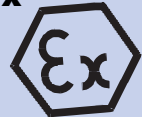

Typical applications of BEKOMAT® V are, for example, air extraction systems, air conditioning plant, and bio-gas installations.

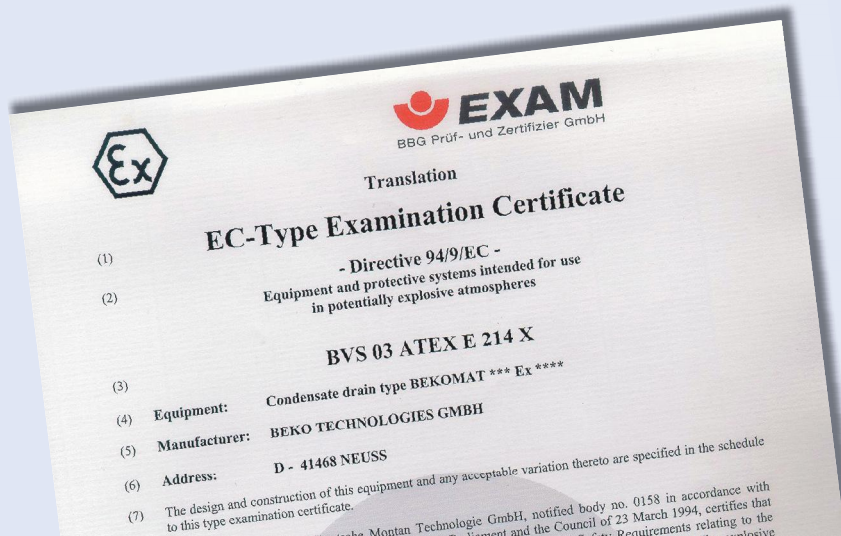

CONDENSATE DRAIN

BEKOMAT® 3 VACUUM

BEKOMAT® 6 VACUUM



FUNCTION

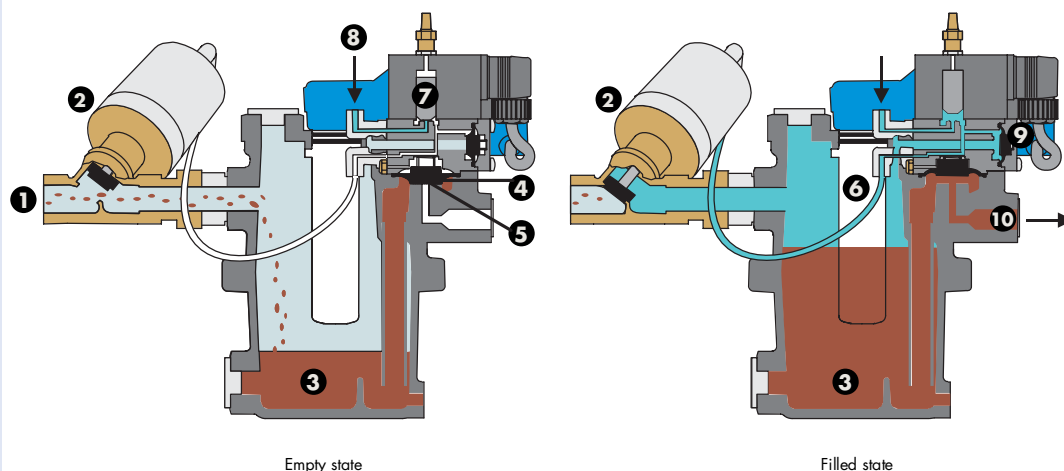

Empty state

Filled state

BEKOMAT® 3 Ex Vacuum shown as an example

Empty state:

Condensate trickles through the inlet opening ① via the open inclined-seat valve ② and collects in the container ③. The diaphragm valve ④ is closed because of the vacuum conditions inside the BEKOMAT® unit and the ambient pressure above the membrane. The larger surface area above the diaphragm results in a high closing force, so that the valve seat ⑤ is tight and leakproof.

Filled state:

When the container ③ has filled with condensate and the capacitive level sensor ⑥ signals at the maximum point, the solenoid valve ⑦ is energized. Via connection ⑧ control gas flows to the inclined-seat valve ②, thereby closing it. The BEKOMAT® unit is filled with control gas via the auxiliary membrane ⑨. Due to the pressure increase the valve diaphragm ④ is opened, and the pressure in the housing then forces the condensate into the discharge pipe ⑩. Finally, the valve ④ is again tightly closed and the inclined-seat valve ② is opened. Should the condensate discharge fail to function properly (blocked discharge pipe, faulty diaphragm), the device will change to the alarm mode after 60 seconds. In this case, the LED flashes and, if desired, the alarm signal is relayed via a potential-free contact. With explosion-protected devices (Ex), this is possible via a built-in optocoupler and a switching amplifier. While in the alarm mode, the solenoid valve will open every 4 minutes for a period of 7.5 seconds. Consequently, a BEKOMAT® unit filled in an unpressurized state will, under pressure, automatically revert to normal operating conditions and thus clear the alarm.

Subject to technical changes without prior notice; the information and data do not represent product characteristics within the meaning of the German Civil Code (BGB)

© Registered trademarks of
BEKO TECHNOLOGIES GmbH, Neuss



BEKO TECHNOLOGIES GMBH

Im Taubental 7
41468 Neuss
Germany

Phone +49 21 31 988-0
Fax +49 21 31 988-900
beko@beko.de

www.beko.de

CONDENSATE DRAIN

BEKOMAT® 3 VACUUM

BEKOMAT® 6 VACUUM



TECHNICAL DATA

Type	Working pressure (bar)		Weight (kg)	Fluid type	Application Housing material	Connections	
	min.	max.				Inlet	Outlet
3 CO V	0.1	1.8	3.4	ö/öf	vacuum aluminium, hard coated	1x G 3/4	1x G 1/2
3 E V	0.1	1.8	7.5	ö/öf	vacuum, stainless steel	1x G 3/4	1x G 1/2
3 CO EX V	0.1	1.8	3.4	ö/öf	ex-protection, vacuum aluminium, hardcoatiert	1x G 3/4	1x G 1/2
3 E EX V	0.1	1.8	7.5	ö/öf	ex-protection, vacuum stainless steel	1x G 3/4	1x G 1/2
6 CO V	0.1	1.8	6.7	ö/öf	vacuum aluminium, hard coated	1x G 3/4 (2x G 3/4)	1x G 1/2
6 E V	0.1	1.8	15	ö/öf	vacuum stainless steel	1x G 3/4 (2x G 3/4)	1x G 1/2
6 CO EX V	0.1	1.8	6.7	ö/öf	ex-protection, vacuum aluminium, hard coated	1x G 3/4 (2x G 3/4)	1x G 1/2
6 E EX V	0.1	1.8	15	ö/öf	ex-protection, vacuum stainless steel	1x G 3/4 (2x G 3/4)	1x G 1/2

ö = oil-contaminated condensate
öf = oil-free, often aggressive
condensate

Type	Nominal throughput* (l/h)			Peak throughput* (l/h)		
	4 bar	6 bar	8 bar	4 bar	6 bar	8 bar
3 CO V	38	42	43	45	45	45
3 E V	38	42	43	45	45	45
3 CO EX V	17	32	37	20	40	45
3 E EX V	17	32	37	20	40	45
6 CO V	171	194	228	200	200	200
6 E V	171	194	228	200	200	200
6 CO EX V	68	137	183	80	150	200
6 E EX V	68	137	183	80	150	200

* Pilot gas pressure

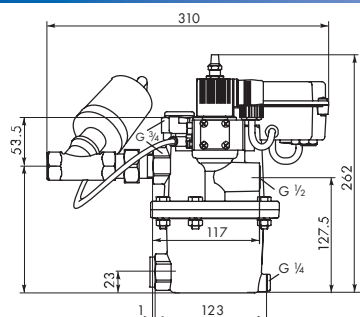

BEKOMAT® 3 EX V

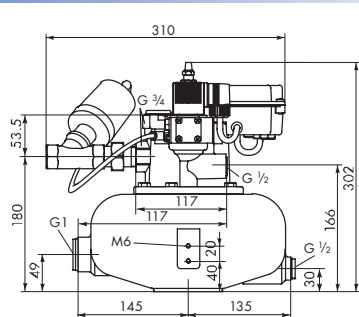

BEKOMAT® 6 EX V

These dimensioned drawings represent examples. Drawings of other versions upon request.